

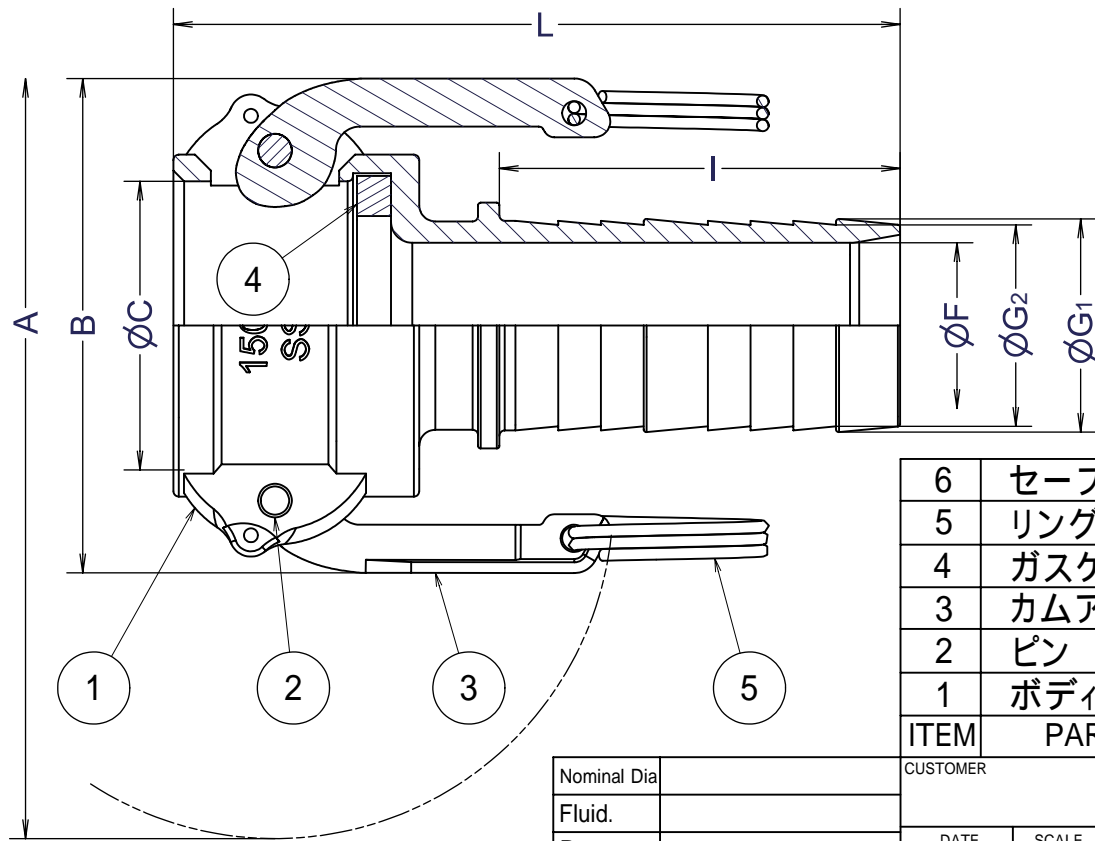

Part No.	75x50-C	75-C	100-C	125-C	150-C	200-C	250-C	300-C	400-C	
Size	mm	20x15	20	25	32	40	50	65	80	100
	inches	3/4x1/2	3/4	1	1 1/4	1 1/2	2	2 1/2	3	4
A		116	116	136	183	191	201	213	266	294
B		54	54	61	85	92	102	114	138	166
ØC		32.4	32.4	37.2	46	54	63.8	76.5	92.2	120.2
ØF		Ø8	14	18.5	25	31	43	55	67	91
ØG ₁		14.7	20.6	27	33.9	39.9	52.8	65.1	77.7	103
ØG ₂		12.7	18.6	25	31.8	37.7	50	62.5	74.5	100
I		42	54	59	61	75	87	88	98	124
L		74	97	109	121	136	158	156	167	197

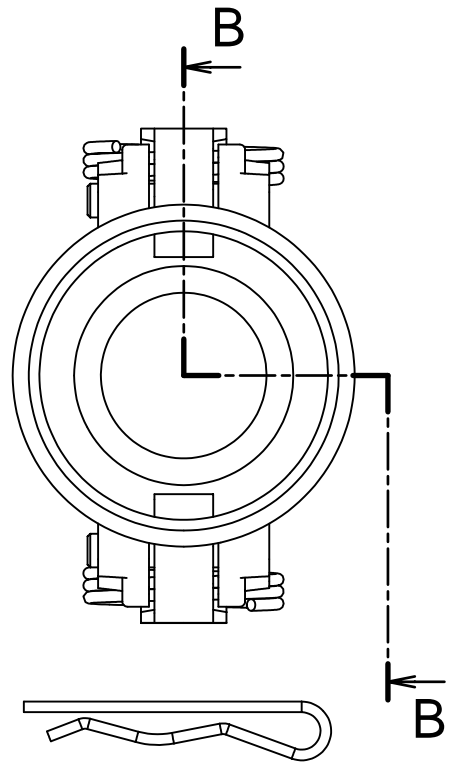

注意
75x50-Cは、ボディとホースタケノコ
の間の凸部はありません。

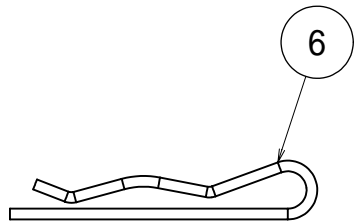
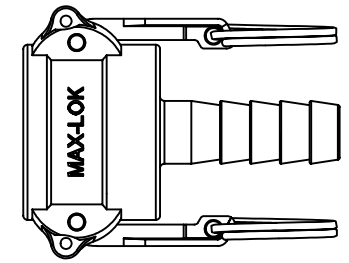

ITEM	PART NAME	MATERIAL	Q'TY	REMARKS
6	セーフティピン	SUS304	2	
5	リング	SUS304	2	
4	ガスケット	NBR	1	
3	カムアーム	SCS16A	2	
2	ピン	SUS304	2	
1	ボディ	SCS14A	1	

Nominal Dia	CUSTOMER				TITLE	
Fluid.					MAX-LOK MAX-C タケノココプラ-	
Press.						
Temp.	DATE	SCALE	DRAW	APPR		
Drawing History	Oct.4'17	none	ToMo			
DWG No.			MAX-C-04SS-73		3	

Section B-B

Units:mm